



GMR48

Double Glass Door Refrigerator Merchandiser



Features:

- Available in black or white exterior
- Aluminum interior
- Stainless steel interior floor for easy cleaning
- Easy-clean PVC liner and quick change shelves
- Heavy duty evaporator fans
- Self-contained refrigeration with a fully ventilated cooling system
- Environmentally-friendly R134A refrigerant
- LED lights keep products illuminated
- Low E tempered double-pane glass and durable PVC frame
- Low-profile easy grab handles
- Top LED illuminated display sign for custom graphics
- Equipped with digital thermostat for accurate and stable temperature
- Oversized bottom back-mount condensing unit for faster cooling
- Positive-seal, self-closing doors with stay open feature



GMR48	
Doors	2
Capacity (Cu. Ft.)	47
Shelves	8
HP	1/3
Amps	4.3
Volts	115
Hz	60
Phase	1
Plug Type	NEMA 5-15
Dimensions	54.4"W x 31.5"D x 83.5"H
Shipping Dimensions	56.22"W x 33.07"D x 86.22"H
Shipping Weight (lb)	419
Net Weight (lb)	397

GMR48

Double Glass Door Refrigerator Merchandiser

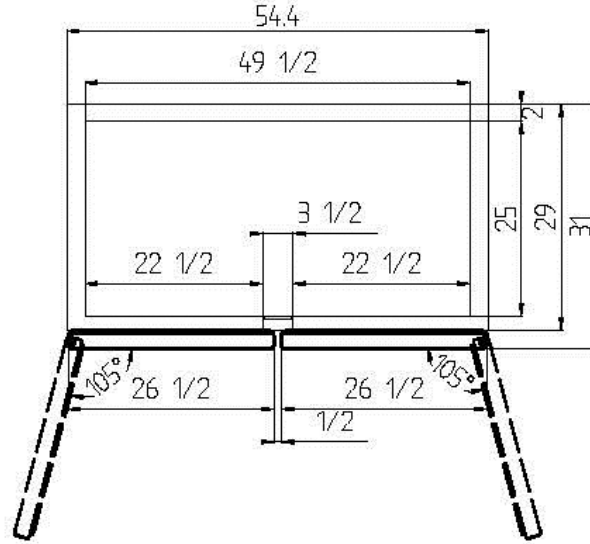

FBGM48F-W
 FBGM48-W
 FBGM48F-B
 FBGM48-B

